

Smoke Detector Camera

Features

- 1/3" High Sensitivity CCD
- 600 TVL Resolution
- Build-in Fixed Lens (f=3.8mm)
- Min. Illumination: 0.05 Lux
- Auto White Balance
- AGC, BLC (on/Off)
- Built-In Audio Function



Specifications

| Model | CV-HS600 |
|--------------------------|---------------------------|
| Signal System | NTSC |
| Scanning System | 2:1 interlace |
| Scanning Frequency(H) | 15.734kHz |
| Scanning Frequency(V) | 59.94Hz |
| Image Sensor | 1/3" High Sensitivity CCD |
| Sync. System | Internal |
| Total Pixels Number | 811(H) x 508(V) 410K |
| Effective Pixels Number | 768(H) x 494(V) 380K |
| Horizontal Resolution | 600 TV lines |
| Video Output Level | 1.0Vp-p (75Ω, composite) |
| Lens | Fixed lens |
| Min. Illumination | 0.05 Lux |
| White Balance | Auto |
| Focus Mode | Manual |
| Electronic Shutter Speed | 1/60~120,000sec |
| Dimensions | 89.5(Ø) x 113(W) x 63(H) |

Dimensions

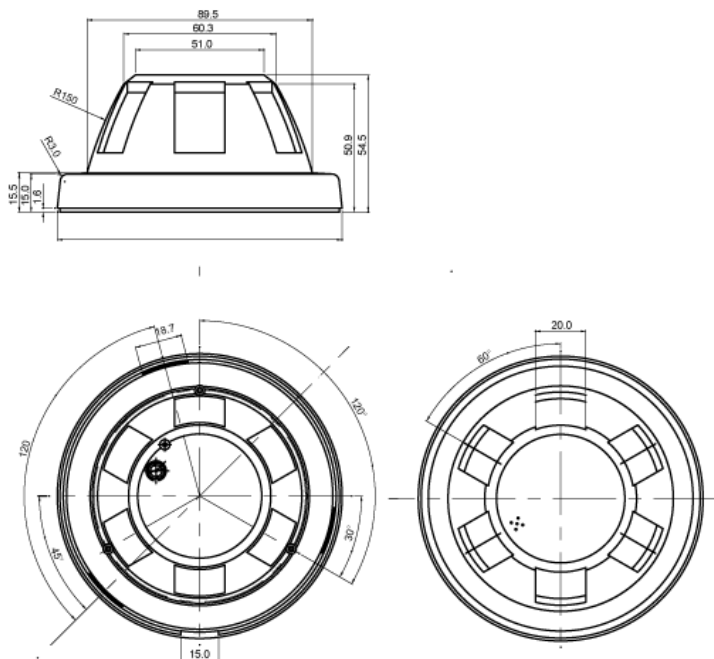

ClearVision and the ClearVision Logo are registered trademarks of ClearVision, Inc.
 Sony is a registered trademark of Sony Corporation
 Product specifications and availability are subject to change without notice.
 ©Copyright 2008, ClearVision, Inc. All rights reserved.